

« ».

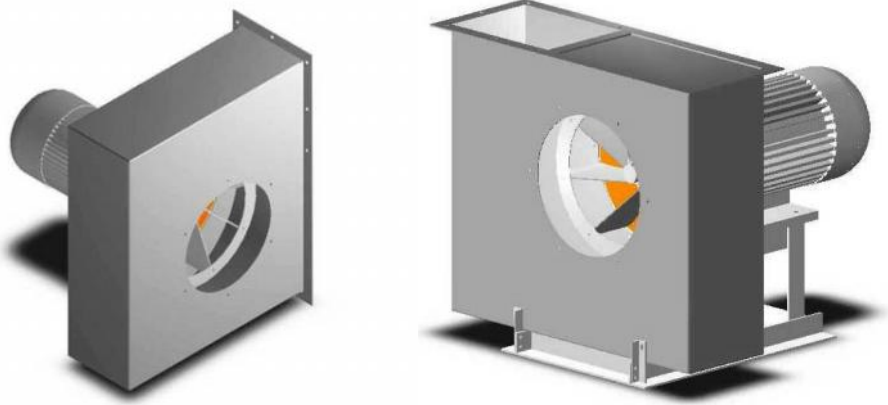

•
•
•
•

- 250 / 3

•
•
•
•
•
•

-10000	1	100L2	5,5	2940	4,8-5,2	2380-2400	78
		5 112 2	7,5	2940	4,8-8,0	2400-2140	110
		132 2	11,0	2940	4,8-10,3	2400-1500	130

	125	250	500	1000	2000	4000	8000	
2940	104	108	107	104	103	97	88	109

Pv, Па

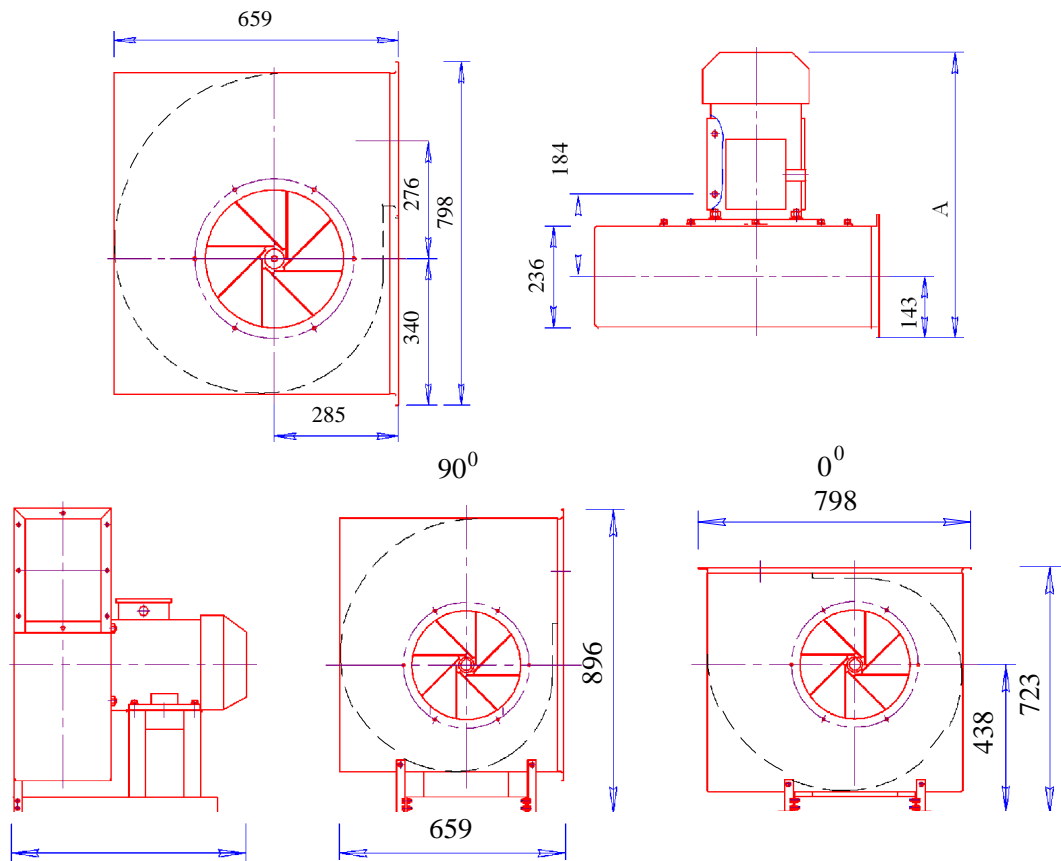
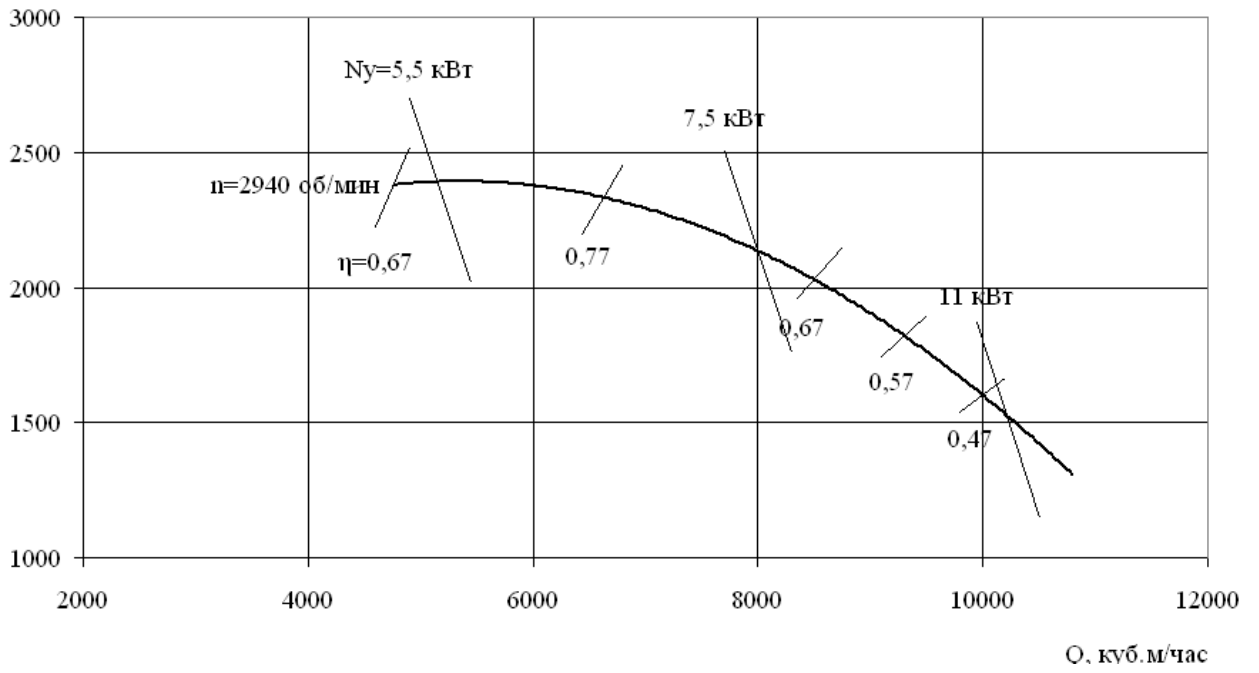

5,5	596
7,5	664
11,0	682

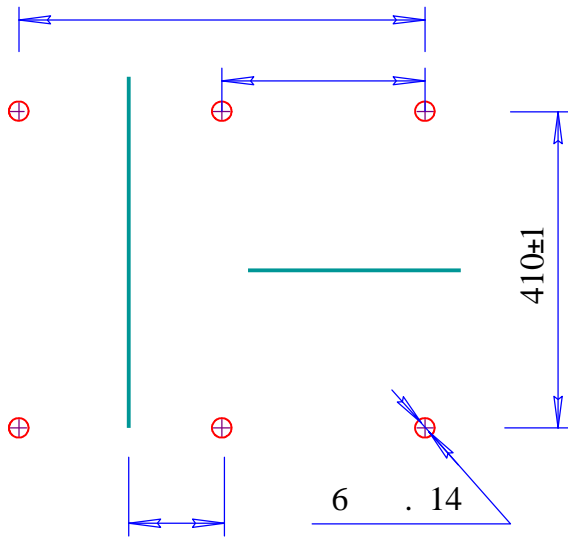
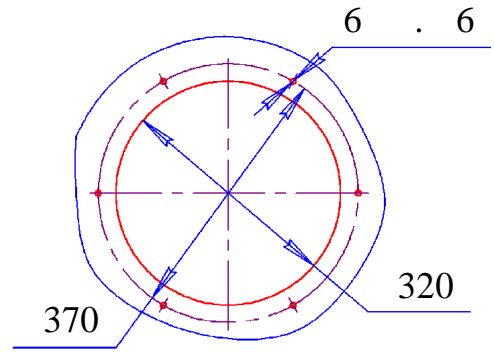
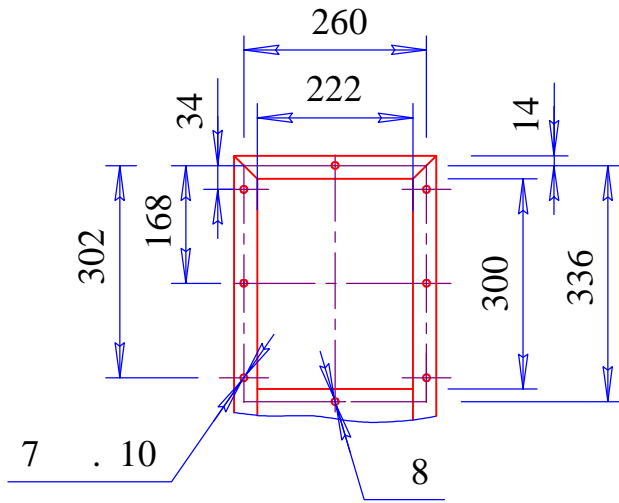

	,	,	,	,
5,5	446	223	124,5	
7,5	472	236	137	
11,0	510	255	156	

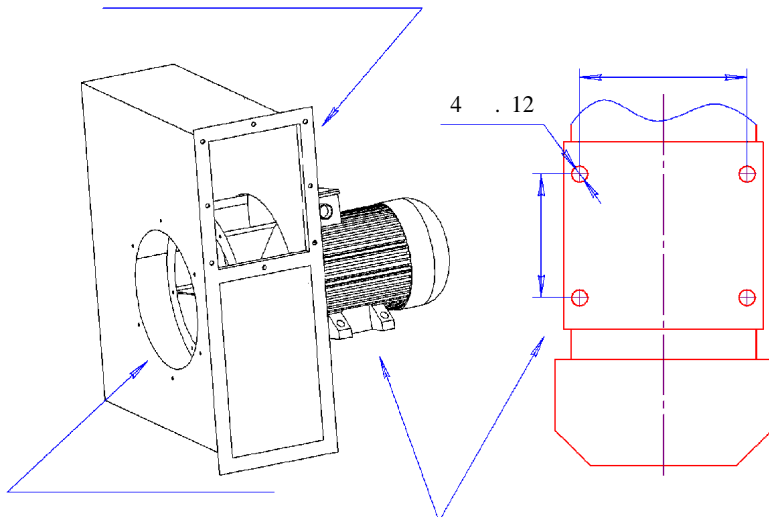

	,	,	
5,5	140	160	
7,5	140	190	
11,0	178	216	